

ASSEMBLY AUTOMATION®

AUTOMATIC SCREWDRIVING SYSTEMS

TRT-1

**Torque Reaction Arm with Power Assist
For Automatic Screw Driving**

DC or pneumatic tools
6 lbs., wt. (2.7 kg)

Rework control

Flexible cable / airline support

Air cylinder / spring support
provides effortless zero-G feel

Various arm lengths available

Optional 2-axis encoders

Ball bearing construction

Trigger Start

Ergonomic swiveling handpiece
eliminates operator fatigue

Powered bit extension
(optional magnetic or vacuum bits for special applications)

**To be used with Assembly Automation's
Screw Feed units SA-1M, SA-1.5, & SA-2.5**



626-303-2777

www.assemblyauto.com

1849 Business Center Dr. Duarte, CA 91010

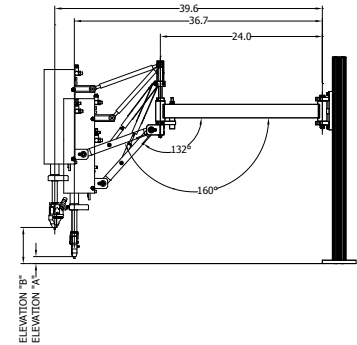
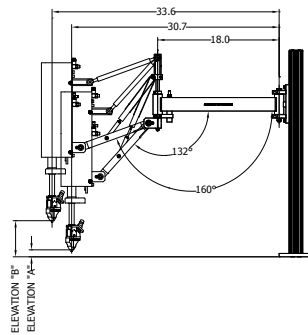
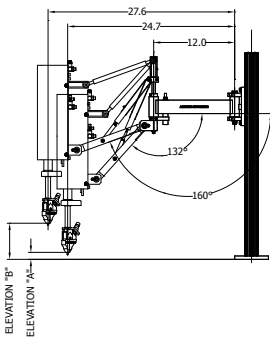
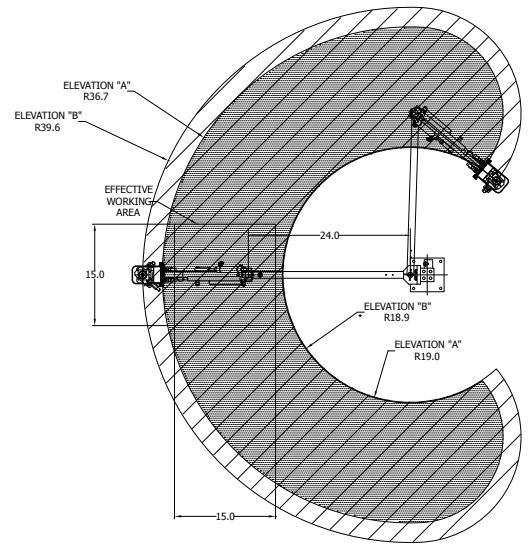
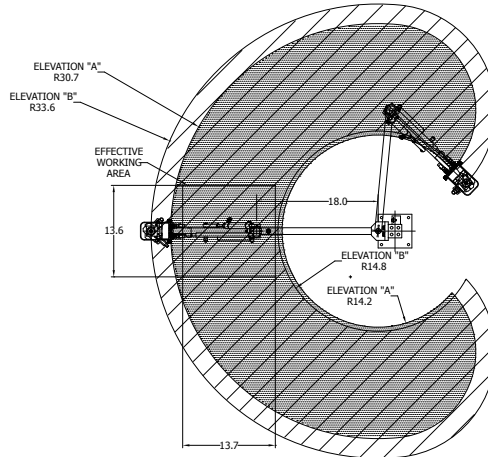
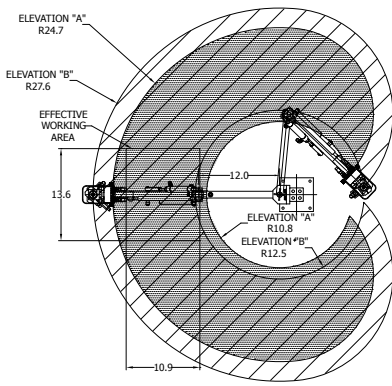

Features

Controlled screw thrust with positive screw extension.



Controlled down assist feature requires no operator down pressure

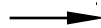

Optional encoders provide positional feedback to ID specific fastener positions.

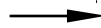

Unique long narrow jaws allow access in areas not possible with other hand pieces.

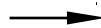

Conveniently positioned trigger on the hand piece provides remote start for air or DC tools.



Rework control allows retorquing without screw feeding



Benefits

The operator can position the fastener easily before screwdriving.

Keeps the bit engaged and reduces fatigue, especially on self tapping applications.

Encoders allow screwdriving sequence to be monitored.

Improves visibility on crowded assemblies with restricted access.

Provides operator control with less than 8 oz. to activate trigger.

May be used to retorque by operating a switch mounted on the hand piece.