

Automatic Screw Feeder

自動ネジ供給機

NSBI Series

Operation Manual (Maintenance)

Read these instructions for the proper use of this machine.
After having read these instructions,
keep them in a convenient place so you
or the operator can refer to them whenever necessary.

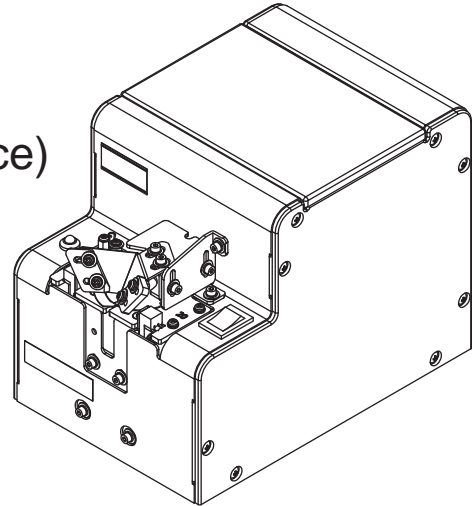

NSBI1MA1 Ma

ATTENTION : www.ohtake-root.co.jp is the only web site associated with our company.
We do not have any branches in China.

各位顾客请注意! : 「www.ohtake-root.co.jp 是敝司唯一的官方网站,
目前, 敝司在中国没有办事处与所谓的中国官网。」

注意! : www.ohtake-root.co.jp が当社唯一の HP アドレスです。
弊社の名を騙る偽サイトにご注意下さい。現在、当社は中国国内に支店はございません。

Contents

1. OVERVIEW OF NSBI Type -----1	7. MISCELLANEOUS ----- 25
2. BEFORE USE -----1	8. TROUBLESHOOTING ----- 26
3. OPERATING PRECAUTIONS -----2	9. SPECIFICATIONS ----- 32
4. NAMES OF MACHINE PARTS ----- 5	10. EXTERNAL DIMENSIONS ----- 34
5. ADJUSTMENTS AND CHECKS BEFORE USE -----6	11. WARRANTY -----35
6. PARTS ADJUSTMENTS AND REPLACEMENTS ---14	

1. OVERVIEW OF NSBI Type

Thank you very much for selecting our Automatic Screw Feeder “NSBI Series”.

This machine can line up screws (Type M1 - M3) and supplies them one by one to increase the efficiency of screw fastening work.

Different sizes of screws can be used by changing the rail, escaper, stopper assembly, escaper guide-right and the passing plate.

It can be used wherever there is a power source for an AC adapter.

2. BEFORE USE

Please check for the following accessories before operating the machine.

- * Operation Manual 1 copy
- * AC adapter 1 unit
- * Screwdriver 1 piece
- * Passing plate 2 pieces (One is already installed.)
- * Hexagonal wrench 1 piece

※ The design, performance and specifications are subject to change without prior notice for the sake of improvement.

3. OPERATING PRECAUTIONS

This manual contains safety alert symbols and signal words to help prevent injuries to the user or damage to property.

◎ Indications



WARNING

This indicates there is a chance of death, serious injury or fire if the instructions are not followed.



CAUTION

This indicates there is a chance of personal injury or damage to property if the instructions are not followed.

◎ Symbols indicating type of danger and preventative measures



Prohibited operation. Never do this!



Do not disassemble, modify or repair.



Do not touch with wet hands.



This indicates to stop operations.



Unplug power supply from wall outlet.



General caution.

When the earth wire is connected, loosen the screw near the  mark once.
After attaching the earth wire, tighten the screw again.



the bottom of the main body

- 2 -



WARNING



Do not disassemble the AC adapter as there is a risk of electric shock, fire or malfunction.



Do not damage, alter or change the power cord. Do not place heavy objects on the cord. Do not pull hard on the cord or twist the cord as it could be damaged, thereby causing a risk of fire or electric shock.



Do not handle the AC adapter with wet hands as it could cause an electric shock.



When using an outlet with AC100 ~ 240V, don't overload the electrical circuit. Do not modify or remodel this machine as this may cause a fire or electric shock.



Do not operate this machine near flammable liquids, gasses or materials as there could be a risk of fire or explosion.















Stop operating the machine and unplug the AC adapter from the wall outlet when you detect smoke, a pungent odor or any other unusual condition, as there may be a risk of fire or electric shock. Contact the dealer, from which you purchased the machine and have it examined and repaired.



In the case of a thunderstorm, stop operating the machine, turn off the power and unplug the AC adapter from the wall outlet. If there is lightning and thunder nearby, move away from the machine and do not touch it or the AC adapter. After the thunder stops, and when it is safe to do so, check the machine. If there is any abnormality, contact your dealer.

- 3 -

CAUTION

-  Use only the AC adapter supplied with this machine otherwise it may result in a fire or electric shock.
-  Do not install this machine in an unstable location otherwise it may fall causing damage or injury.
-  Always operate the machine with the upper cover in place, otherwise it may result in injury.
-  Do not allow any foreign material to enter the machine while in operation.
Do not put your fingers into the machine while in operation, otherwise an injury will result.
-  Do not operate this machine in overly humid or dusty conditions.
Keep the plug socket clean at all times otherwise it may cause a fire or electric shock.
-  When moving the machine, always disconnect the AC adapter from the wall outlet or it may result in damage to the cord, or cause a fire or electric shock.
-  Turn off the machine and unplug the AC adapter from the wall outlet during closing hours or if the machine will be unused for any extended period of time.
-  When performing maintenance, changing parts or when you sense an abnormality in the machine, turn the power off and pull the AC adapter from the wall outlet.
-  Do not operate the machine with tension on the AC adapter cord.
Keep the cord loose and untangled.
-  Do not bend, alter or damage the rail. Do not apply any oil. It is recommended that the user clean the rail periodically.
-  Do not use any screw that is out of the specified range nor any screw that is oily or dirty.
-  When pick uping screws, do not exert excessive force or shock to the screws.

- 4 -

4. NAMES OF MACHINE PARTS

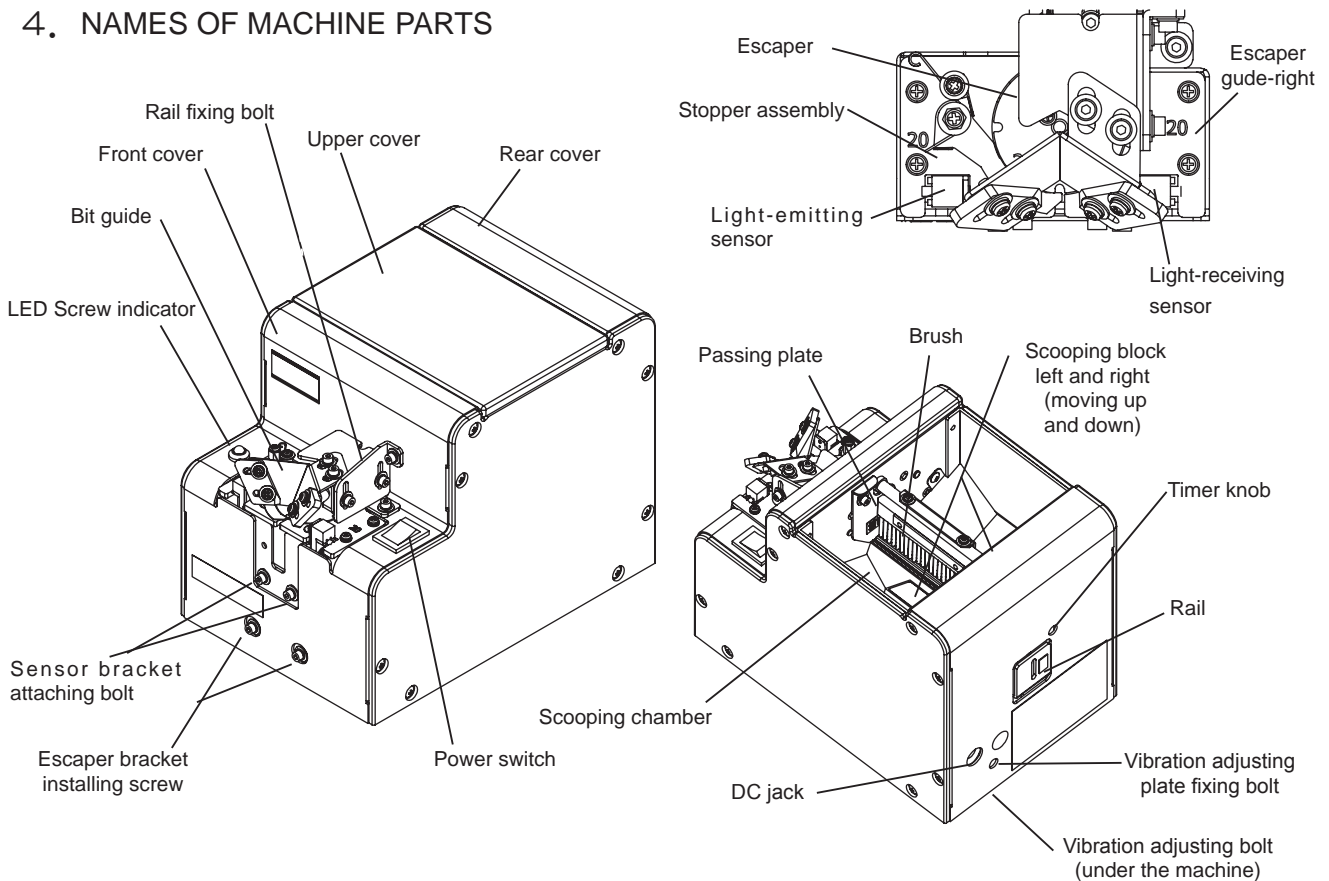

- 5 -

5. ADJUSTMENTS AND CHECKS BEFORE USE

5- 1. Checking the model number of the main body

Check if the machine has the parts which match the nominal diameter of the screws to be loaded. Check the model number of the rail, escaper, stopper assembly, escaper guide-right and passing plate by referring to the following table. Each escaper, stopper assembly and escaper guide-right is stamped with a model number which corresponds with the type of screws that can be used.

Screw feeder series	Screw feeder model	Screw size	Exchange kit No.	Rail model No.	Escaper model No.	Stopper assembly model No.	Escaper guide-right model No.	Passing plate model No.
NSBI	NSBI10	φ 1.0	BI10SET	BI10	SIE10	SIES10	SIEM10	SW1017
	NSBI12	φ 1.2	BI12SET	BI12	SIE12	SIES12	SIEM12	
	NSBI14	φ 1.4	BI14SET	BI14	SIE14	SIES14	SIEM14	
	NSBI17	φ 1.7	BI17SET	BI17	SIE17	SIES17	SIEM17	
	NSBI20	φ 2.0	BI20SET	BI20	SIE20	SIES20	SIEM20	
	NSBI23	φ 2.3	BI23SET	BI23	SIE23	SIES23	SIEM23	SW2030
	NSBI26	φ 2.6	BI26SET	BI26	SIE26	SIES26	SIEM26	
	NSBI30	φ 3.0	BI30SET	BI30	SIE30	SIES30	SIEM30	

Note: Screws, with a different nominal diameter, can be used by replacing the rail, escaper, stopper assembly, escaper guide-right and passing plate. The parts, for replacement, are available separately.

Before delivery, each section of the machine is checked and adjusted with panhead screws matching the nominal diameters of the ordered model. Most screws may be usable in the initial status of adjustment however, if the height or shape of the screw head is different or if the operation is regarded as abnormal, each section must be readjusted. If this is the case, make the following checks and adjustments:

- Check the screw load amount
- Check and adjust the brush
- Check and adjust the passing plate
- Check and adjust the rail vibration
- Check and adjust the holding plate
- Check and adjust the front & rear sides of the rail
- Check and adjust the timer

If the rail, escaper, stopper assembly, escaper guide-right and passing plate, of the machine, are replaced, screws with a different nominal diameter can be accepted. After these parts are replaced, fine adjusting is required. The respective adjusting procedures will be described elsewhere. Please read these procedures.

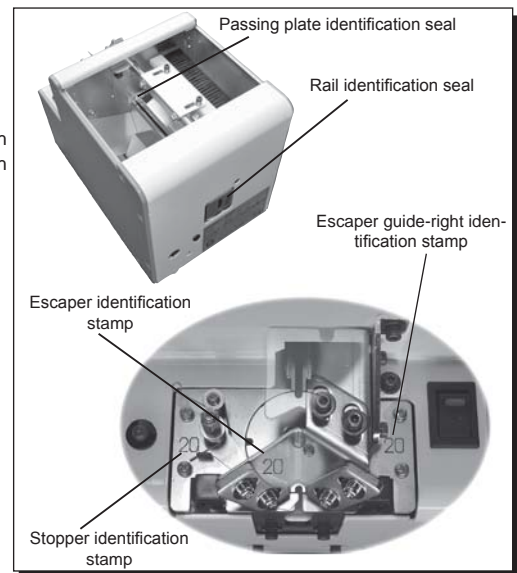

- 6 -

5- 2. Amount of screws to be loaded

An excessive amount of screws, loaded into the chamber, will have an adverse effect on the screw alignment and transport. The figure, shown at right, indicates the maximum amount of screws to be loaded. Use this as a guide when loading the screws.

- Turn the power switch ON and OFF so that the scooping block is at the lower limit position.
- Load screws up to approximately 2 ~ 3mm below the rail surface.
- At this time, check that screws are not loaded so as to cover the upper portion of the inclined plate.
- Be sure to determine the screw load by observing the machine while it is in operation.

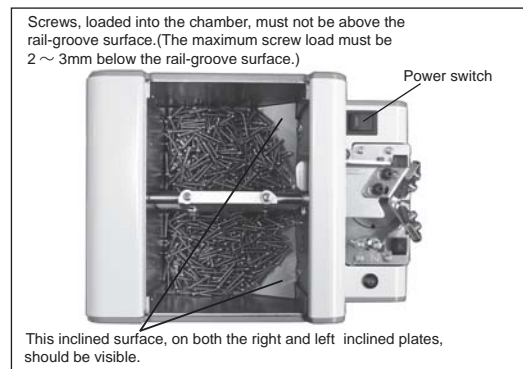

5- 3. Checking and adjusting the brush

! Turn OFF the power supply before checking and adjusting.

Load the screws into the scooping chamber, turn ON and OFF the power switch so that screws are aligned into the rail groove.

- Turn ON and OFF the power switch so that the brush bristles are in a horizontal position as shown in the figure at right.
- Check that the heads of the screws, in the rail groove, are in slight contact with the brush bristles.
- When the brush height is too high or low, this will have an adverse effect on the screw alignment and transport.
- If any adjustment is necessary, loosen the brush height adjusting bolt to adjust the brush height.
- If the plastic portion, at the front of the brush, comes into contact with the passing plate, loosen the brush assembly mounting screw and make an adjustment either backward or forward.
- Operate the machine to check that the brush operation is normal.

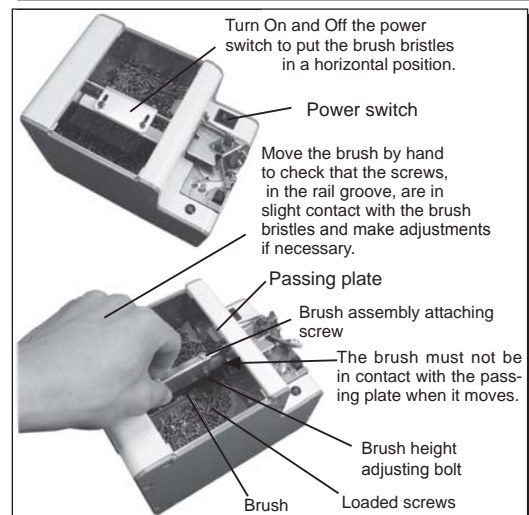

- 7 -

5- 4. Checking and adjusting the passing plate

! Turn OFF the power switch before making any checks or adjustments.

- Check that the passing plate is adjusted to a height that permits loaded screws to pass just within the clearance limit.
- If the passing plate is too low, screws cannot pass.
- If the passing plate is too high, it will hamper a smooth transport of the screws.
- If adjustment is required, loosen the passing plate attaching bolt and adjust the height.
- After making an adjustment, do an operational check.

Note: Using the half-presses on both sides of the passing plate as guides, slide the passing plate up or down.

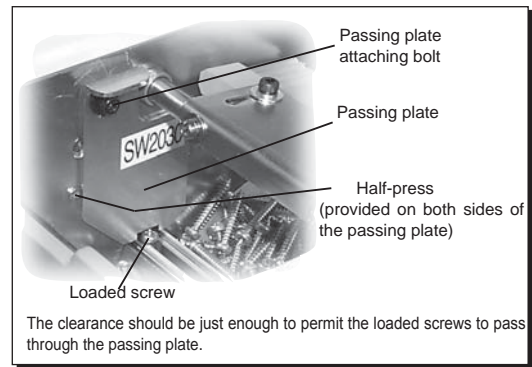

5- 5. Checking and adjusting the rail vibration

This machine's rail vibration can be adjusted.

The screw transport speed differs depending on the screw type.

Check the screw transport speed. If the rail vibration hinders a smooth transport of the screws, it can be adjusted.

- Loosen the anti-vibration bolt at the rear of the machine. Next, turn the vibration adjusting bolt, located on the bottom of the machine, to adjust the vibration. When the bolt is turned clockwise, as viewed from the bottom of the machine, the vibration will increase. When the bolt is turned counterclockwise, the vibration decreases.
- If the vibration is adjusted to a too large a value to increase the transport speed, the rail will hit against the escaper and screws may fall into the machine from the clearance, failing to unload screws normally. Adjust the vibration to a proper value that matches the loaded screws. (Related item: Check and adjust the front and rear positions of the rail.)
- After making an adjustment, be sure to tighten the vibration plate fixing bolt.
- After making an adjustment, do an operational check.

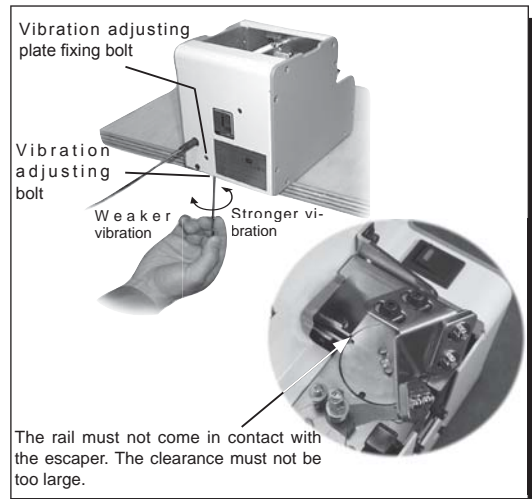

- 8 -

5- 6. Checking and adjusting the height of the bit guide bracket

Check the height of the bit guide bracket.

- Check that the clearance between the head of the loaded screw, in the rail groove, and the bit guide bracket is 0 ~ 1mm.
- If there is no clearance, a screw will be caught.
- If the clearance is too large, a screw pile or screw jump will occur.
- If adjustment is required, loosen the bit guide bracket attaching bolt and make an adjustment either up or down.
- If the bit guide bracket hits against the escaper, it will hinder the escaper motion.
- After making an adjustment, check the machine operation.

5- 7. Checking and adjusting the front/rear position of the rail

If the rail comes into contact with the escaper, or the clearance between the rail and escaper is too large, when the machine is operated, loosen the rail fixing bolt and adjust the rail either backward or forward. After making an adjustment, be sure to tighten the rail fixing bolt.

- If the rail hits against the escaper, the escaper will not function properly.
- If the clearance between the rail and the escaper is too large, screws may fall into the machine.

After making an adjustment, try making a vibration readjustment by referring to "Checking and Adjusting the Rail Vibration."

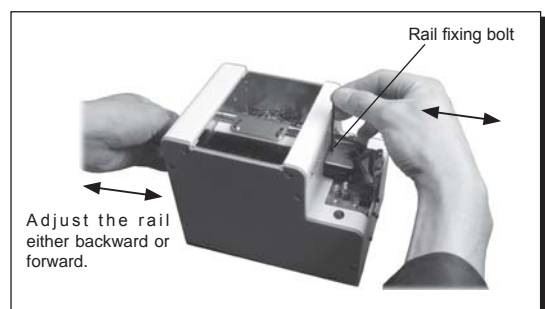
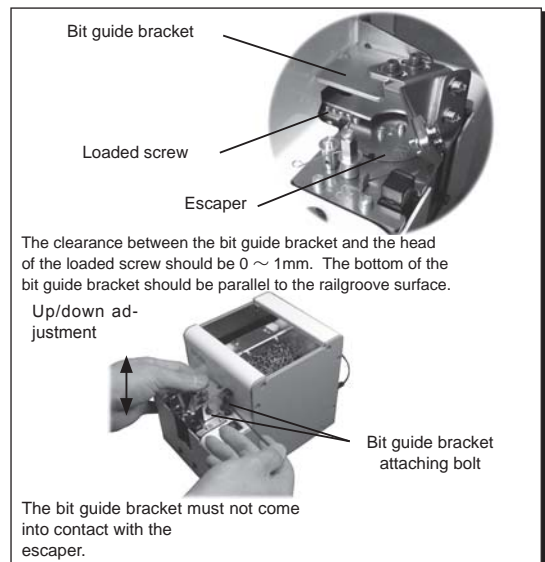

- 9 -

5- 8. Checking and adjusting the bit guide

Check the bit guide position.

- Adjust the bit guide to a position where the user can easily pick up screws.
- Try picking up screws a few times in order to adjust the position of the bit guide.
- Adjust the bit guide by loosening the attaching bolts.

⊙ Adjusting the guide plate

- When it is difficult to pick up screws with the bit, adjust the guide plate.
- Loosen the guide attaching screw and adjust the guide plate by inserting the bit being used.
- After adjustment, check if pick up, with the bit being used, is smooth.

⊙ Adjusting the groove between the bit guide and the guide plate.

- The groove position between the bit guide and the guide plate should be such that it is easy for the user to pick up screws.
- Adjust the groove position by loosening the bit guide attaching bolt.
- After adjustment, check that the pick up of screws is smooth.

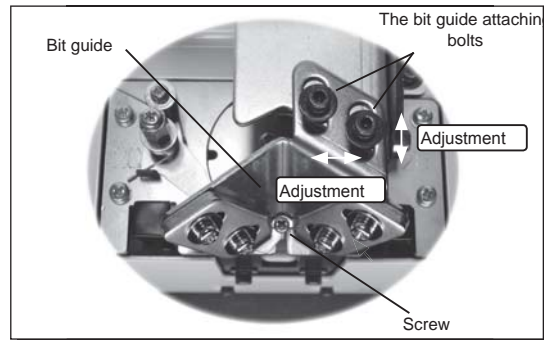
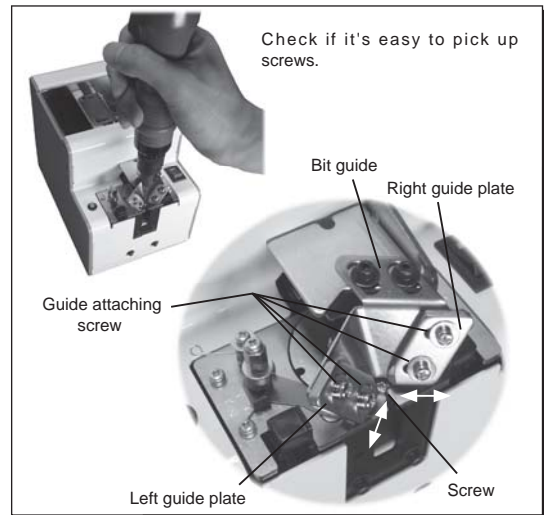

- 10 -

5- 9. Checking and adjusting the timer

The screw transport feed differs depending on screw type. This machine can make screw unloading smooth through timer adjustment. For screws with a low transport speed, set the timer long. For screws with a high transport speed, set the timer short.

- This machine continues its operation when no screw is found at the screw pick up site. The machine continues operating with a screw at the pick up site but will stop, after a certain lapse of time, if the screw is not picked up.
- This time lapse can be varied by adjusting the timer.
- After the screw is picked up, the machine starts operating again.
- Check the operation by intercepting the optical axis of the sensor.
- When there is a screw present in the escaper with the main power ON, use a finger or an object to block out the ultrared sensor, and switch on the power again.
- Make an adjustment with the timer knob at the rear of the machine body (as shown in the figure on the right).
- When the timer knob is turned clockwise, as viewed from the rear side, the time becomes shorter.
- When the knob is turned counterclockwise, the lapse time becomes longer.
- Make this adjustment, by using the accompanying screwdriver, within the allowable turning range, without using excessive force.
- Do an operational check with screws loaded in the scooping chamber and set the timer properly.

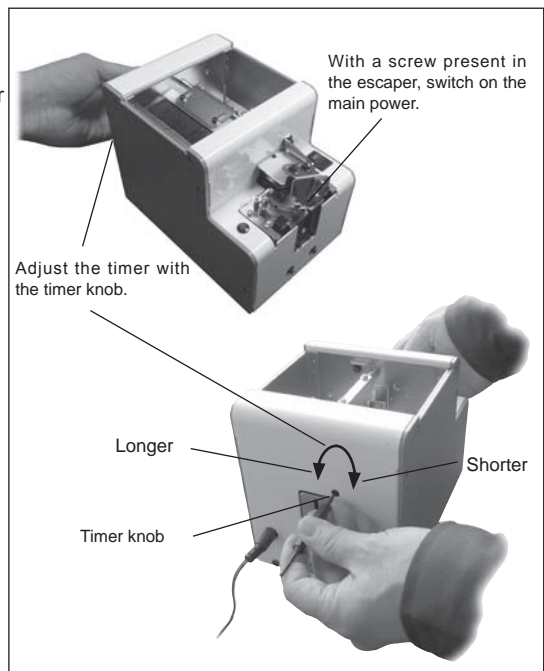

5- 10. Operation

○ Loading the screws (cf. p7)

- Open the upper cover.
When the chamber plates are at their lowest position, load screws up to 2 ~ 3mm below the rail groove surface.
 - Check that the screws are not loaded so as to cover the upper portion of the inclined plates.
- [CAUTION] Do not overload the chamber with screws otherwise it may cause a malfunction or damage the machine.

- 11 -

○ Turning ON the power

- Plug the attached AC adapter into the main body and power outlet.
[CAUTION] Do not use any AC adapter other than the one included with this unit, as it may cause damage.
- When the power switch is turned ON, the power switch lamp lights up. The scooping block starts to move up and down. The rail starts to vibrate and the escaper starts rotating.
- Screws move along the rail towards the rotating escaper which selects one screw at a time.
- The escaper rotates and deposits the selected screw at the pick up site.
- At this moment, the sensor detects a screw and the screw sensor LED lights up and then the operation stops.
- Until a screw is picked up, the machine stops operating.
- When a screw is picked up, the sensor detects this and the sensor LED light goes off and the machine resumes operation.

○ Pick uping Screws

- Screws can be picked up with an electric screwdriver using a magnetized bit.
- Use the bit guide to put the screwdriver down vertically into the screwhead's slots, then pull the screwdriver, horizontally, towards you as pick uping the screw.
To insert the screwdriver bit into the screwhead slots properly, it may be necessary to twist the driver slightly.
- When inserting the screwdriver into the screwhead slots, do not use excessive force as it may alter the position of the escaper or cause damage to the machine.

[Reference] Refer to the following table for the recommended bit sizes.

Model	Screw size	Screwdriver Bit Size	
		Bit Tip Diameter	Cross Slot No.
NSBI10	φ 1.0	φ 1.5	No.0
NSBI12	φ 1.2		
NSBI14	φ 1.4		
NSBI17	φ 1.7		
NSBI20	φ 2.0	φ 2.0	No.0 or No.1
NSBI23	φ 2.3		
NSBI26	φ 2.6	φ 3.0	No.1
NSBI30	φ 3.0	φ 3.2	No.1 or No.2

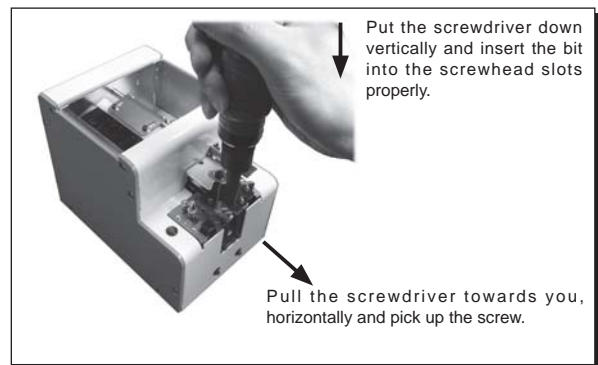

5-11. Maintenance

A dirty rail groove may interfere with the screw transport speed. Clean the dirty rail with a soft, clean cloth dipped in alcohol. If cleaning is difficult, remove the rail from the machine and clean the rail groove. Before removing the rail from the machine, be sure to turn off the power supply and take the screws out of the chamber. If there is any dirt or a flaw in the rail groove that may cause an impediment in use, we recommend the user to replace the rail.

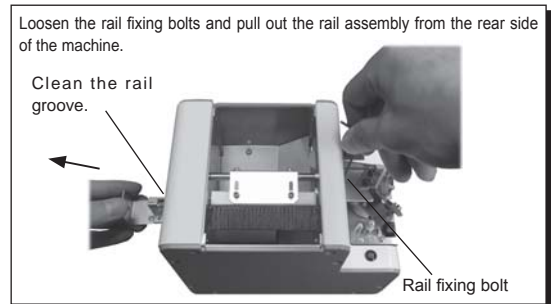

5-12. Installing the additional "Nejikura" Screw hopper

We have, as an attached unit, "Nejikura" which supplies a measured amount of screw loading, automatically. To use "Nejikura", take off the upper cover of the screw feeder NSBI type and put on "Nejikura".

"Nejikura"

- Detects, by sensor, the amount of screws in the scooping chamber of the screw feeder.
- Continues to supply screws automatically as the sensor detects the amount of screws, in the scooping chamber, to be decreasing.
- two other "Nejikura", that fit the NSBI type, are the SR-80 Floor type(Table-Top) and the T-510S Tower type.
- If space above the screw feeder is limited, choose the SR-80 Floor type(Table-Top), if there's enough space above, choose the T-510S Tower type.

To order, please contact your dealer.

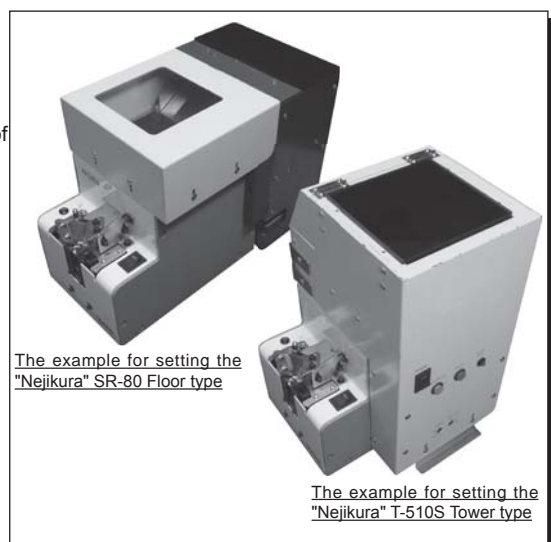

6. PARTS ADJUSTMENTS AND REPLACEMENTS

The brush and main motor are consumable parts. When using a different diameter of screw, the following items must be replaced: rail, stopper assembly, escaper and escaper guide-right. These parts may be ordered separately. The replacing and adjusting procedures are described below. When replacing any parts, a fine adjustment is required. Make these fine adjustments by reading the corresponding contents carefully. Before replacing any parts, be sure to remove all the screws from the chamber.

6- 1. Replacing and Adjusting the Brush

- ❗ Turn OFF the power switch before starting replacement and adjustment.

If the brush is too worn to sweep screws off of the rail, replace it. A brush with harder bristles, than the standard brush, is available as an option.

- Turn ON and OFF the power switch in order to set the brush at the position shown in the figure on the right and detach the brush assembly.
- The brush assembly can be disassembled as shown in the figure on the right.
- For assembly, reverse the disassembling procedure.
- After completing the assembly, check that the front part of the brush doesn't come in contact with the passing plate. The ideal clearance is 0mm.
- For adjustment, refer to "Checking and Adjusting Before Operating the Machine".

Part number of brush assembly:

- NSB 02053 #01 (standard brush)
- NSB 02053 #02 (optional, harder bristle brush)

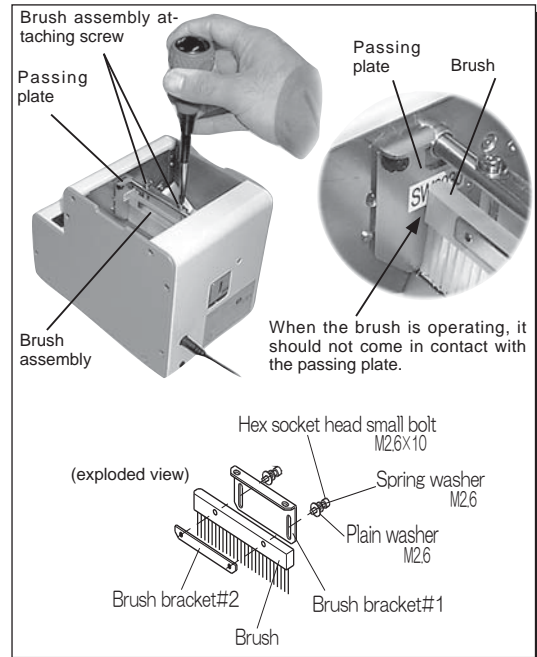

- 14 -

6- 2. Replacing the Main Motor

- ❗ Turn OFF the power switch before starting to replace and adjust the main motor.

When the motor is damaged, replace it with a new one.

- First, remove the cover from the main body. Then, disconnect the connectors for the power switch and LED screw indicator. This makes it easier to work within the body.
- Disconnect the motor junction connector.
- Remove the motor attaching screws on the bottom of the main body.
- Pull out the motor from the rear side of the main body. (If the motor is hard to pull out, insert an Allen wrench into the oblong hole in the base of the body and push the motor bracket backward.)
- The motor can be disassembled as shown in the figure on the right.
- For reassembly, reverse the disassembling procedure. The combination of the operation timing for the left and right scooping blocks is shown on the next page.

Note: Do not use excessive force with the motor wiring in order to avoid wire breakage.

Part number of main motor unit : NSIB 7115

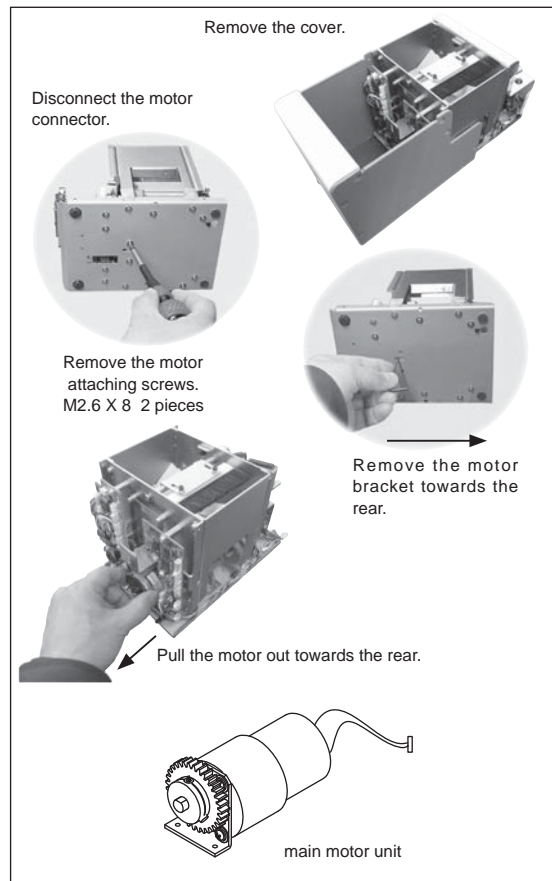

- 15 -

○ Operation Timing After Replacing the Main Motor

! Turn OFF the power switch before starting to replace and adjust the main motor.

- To adjust the timing of the scooping block in respect to the brush movement, it is necessary to adjust the gear engagement.
- When the motor has been removed from the main body, adjust the gear engagement of the motor, as shown in the figure on the right, then the operation timing can be adjusted.
- When it is hard to engage the driving gear, of the motor, with the driven gear, loosen the drive shaft bracket (right) then this will facilitate the assembly. (Refer to the figure on the right.) After assembling the motor, be sure to tighten the screws again.
- After installing the motor, switch the power ON to check the operation timing. (Check that both right and left scooping blocks operate almost simultaneously.)
- After doing an operation check, return the wiring arrangement to its original status. When installing the cover, be careful not to pinch any wires. Be careful that the wiring does not hinder the operation of moving parts. The wiring, on the inside, should not hinder adjustment made from the outside of the machine.

NOTE:

To avoid breakage, do not use excessive force with the motor wiring.

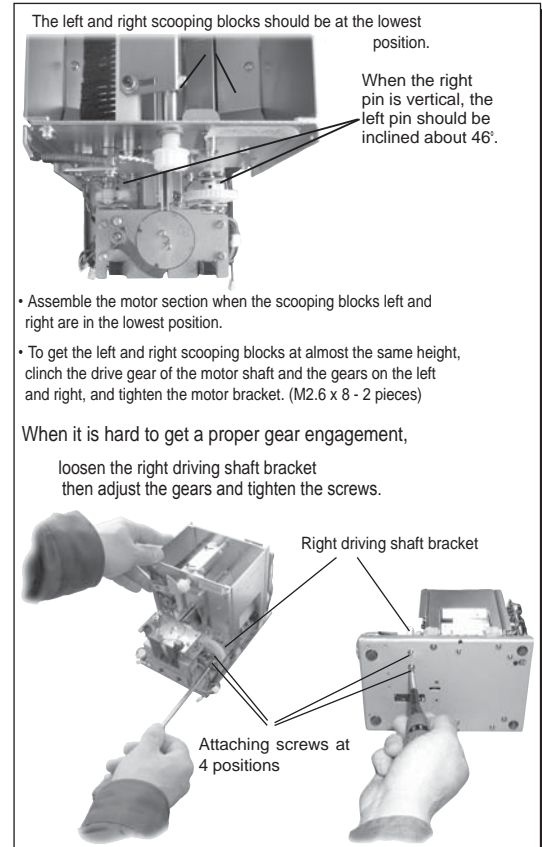

- 16 -

6- 3. Replacing the rail

! Turn OFF the power switch before starting to replace and adjust the rail.
Before replacing, remove all the screws from the hopper, the rail, and the escaper.

The rail of this machine can be easily replaced.

If there is any dirt or flaw on the rail groove that prevents a smooth operation, we recommend the user clean or replace the rail.
Use the passing plate, rail and escaper that correspond to the diameter of the screws loaded.

Loosen the rail fixing bolts and pull out the rail assembly from the rear of the machine. After replacing the rail, each part must be adjusted.

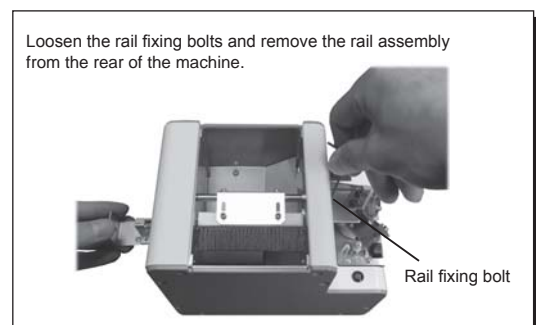

6- 4. Replacing the Passing Plate

! Turn OFF the power switch before starting to replace and adjust the rail.

Use the passing plate, rail and escaper that correspond with the diameter of the screws loaded.

The following are passing plate numbers which correspond with the model numbers:

1.0 ~ 1.7 corresponds with Model No. SW1017

2.0 ~ 3.0 corresponds with Model No. SW2030

Please check that the model numbers correspond with the screws that can be used.

Remove the passing plate. Do not lose the attached bolts. Using bolts other than those supplied with this machine may result in a malfunction. When installing, use the half-press on both sides of the passing plate as guides. After replacement, make the adjustments that correspond with the screws loaded.

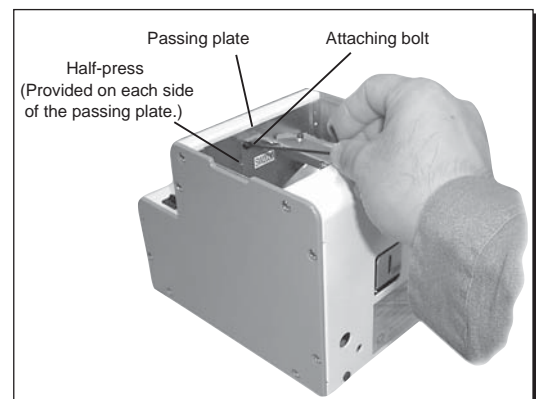

- 17 -

6- 5. Replacing and adjusting the escaper, the stopper assembly and the escaper guide-right

- ❗ Turn OFF the power switch before replacing.
- Turn ON the power switch when adjustments are necessary.
- Before replacing, remove all the screws from the hopper, the rail, and the escaper.

When using screws with a different diameter, replace the escaper, the stopper assembly, the escaper guide-right, the rail and the passing plate.

First, remove the bit guide attaching plate and then replace and adjust the parts.
After replacement, be sure to adjust and check the parts in the area of the escaper.
When you remove the escaper attaching screw, please use the driver for M2 (bit No.0).

(Summary of the adjustment)

Adjust moving parts to correspond with the rail.
In terms of height, the level of the escaper surface should be lower than the level of the rail surface.
Line up the rail groove with an escaper notch at the end of the reference point run. A reference point run is the detecting of the starting point of the escaper motor rotation. Also, make sure there is no contact with the side of the rail and the robot escaper guide.

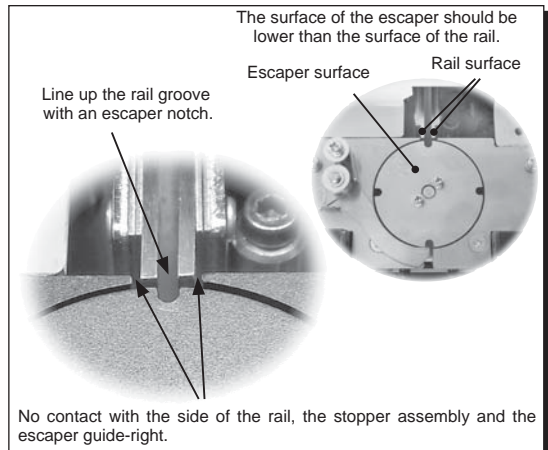
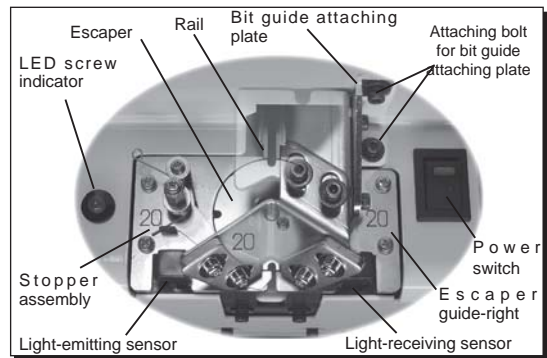

- 18 -

①. Replace the escaper, stopper assembly and escaper guide-right.

Before replacement, remove any screws that were loaded in the chamber.

First, remove the bit guide attaching plate, then replace and adjust the parts.

As looking at the front of the machine, start by removing the parts from the right side.
Start by removing, in this order:

the escaper guide-right → escaper
→ Spring holder (fixing the stopper assembly with screws) → stopper assembly.

When you remove the Spring holder, you can remove the flathead screw under the stopper. Do not lose the attaching screws.

For assembly of the replacement parts, reverse the disassembly procedure.
After installing the Spring holder, assemble the spring as shown in the figure at right.

The escaper notch needs to be adjusted to the rail groove position later. Assemble the escaper loosely as it will need adjusting later.

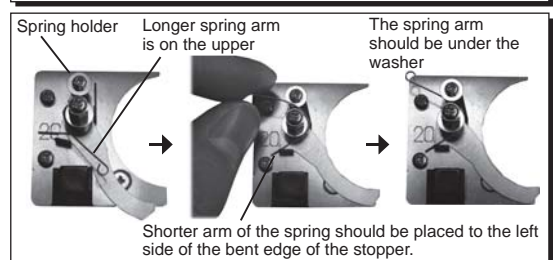
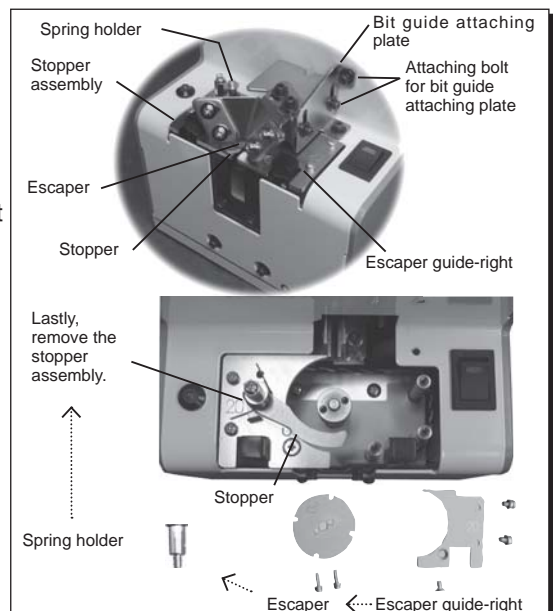

- 19 -

Check the movement of the stopper before adjusting the parts in the area of the escaper.

- The stopper should not be on the escaper.
- Rotate the stopper by hand, when released, it should return by means of spring action.
- The stopper should be attached to the metal plate of the stopper assembly.

②. Check and adjust the position of the escaper in relation to height and clearance.

Check that the clearances on the outside of the rail, between the stopper assembly and the escaper guide-right are almost even.

If they are in contact, the screws cannot be delivered. If there is too much clearance on either side, screws may fall into the machine.

When the clearances are not even, loosen the escaper bracket attaching bolt and adjust so that the clearances on the left and right of the rail are even.

At this time, make the top surface of the escaper even to or slightly lower than the rail surface. If it's too high, a screw won't enter an escaper notch. If it's too low, a screw will not enter a notch properly.

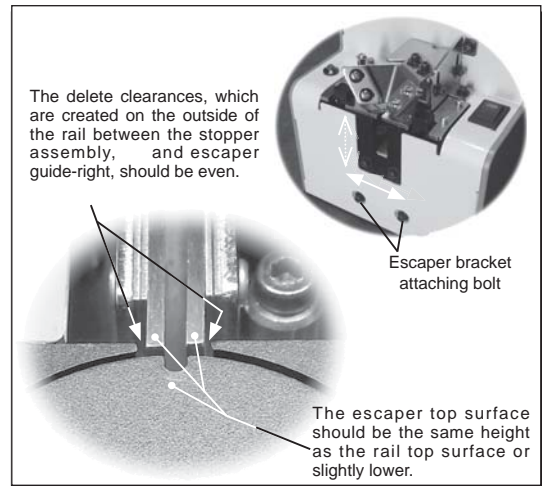
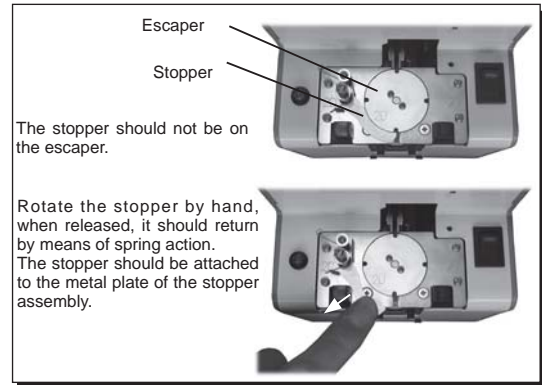

- 20 -

③. Adjust the escaper notch position.

Turn the power switch ON while covering the sensor light axis. When the power is ON, the screw sensor LED lights up and the escaper motor moves around to the back, to the starting point. (Reference point run.) When the escaper motor is at the reference point, the escaper doesn't move. When it is not at the starting point, the escaper motor moves oppositely around to return to the starting point and then stops. (Reference point run.)

- ※ Before adjustment, the starting point for the escaper motor and the position of the escaper notch are not the same.
- ※ A reference point run is the detecting of the starting point of the escaper motor rotation.
- ※ Cover the sensor's optical axis with a piece of paper.

When the power is on, the escaper motor has the ability to remain stationary. Make a reference point run-and-stop and when the escaper motor is stationary, then you can align the position of an escaper notch with the rail groove.

Fine adjustments can be made for the clearance between the end of the rail and the escaper by loosening the screws, on either side of the center of the escaper, and moving the escaper to an ideal position. Remember to tighten the screws again.

After adjustment, turn the power switch OFF/ON in order to make a reference point run and check that an escaper notch and the rail groove align. After, remove the paper blocking the sensor's optical axis and the escaper will start rotating.

Check that all 4 notches of the escaper, each in rotation, stop at the rail groove.

[Reference] It is possible to adjust, finely, the groove section as you adjust the position of the escaper bracket. However, to do so, you must do as follows: * See ② "Check and Adjust "on page 20.

- There must not be any contact between the rail, the stopper and the escaper guide-right. Being in contact stops feeding the screws.
- The escaper top surface should be the same height as the rail top surface or slightly lower.

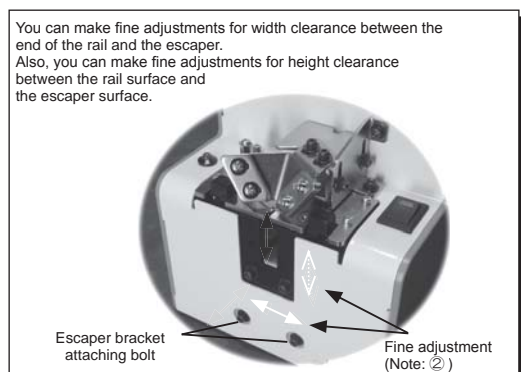
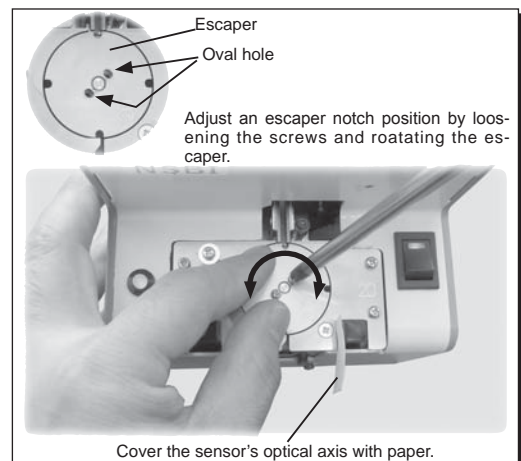

- 21 -

④. Explanation of the escaper movement before adjusting the sensor

When the power switch is turned ON, if there is no screw at the site where the screw is to be picked up, the escaper rotates with the screw sensor LED off.

The escaper rotates and accepts a screw from the rail. As the escaper rotates, it brings the screw to the screw pick up site. At this time, the sensor detects the screw, the LED lights up and the escaper stops.

When the screw is removed from the pick up site, the LED light goes off and the escaper rotates.

This is the correct sequence of operation. Usually, there is no need to adjust the sensor as it was done when assembled in the factory.

The following are irregular situations that require adjustment:

- There is no screw at the pick up site but, the LED is on and the escaper doesn't rotate.
- There's a screw at the pick up site, but the LED is not lit and the escaper rotates.

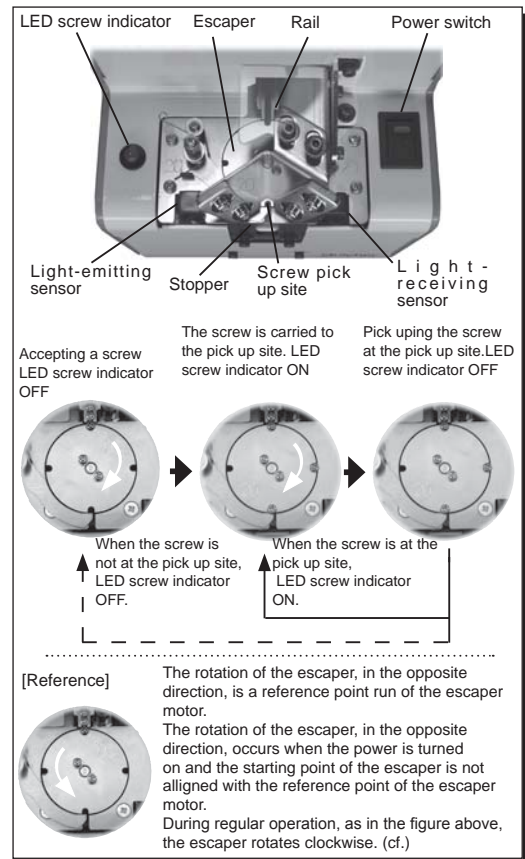

- 22 -

⑤. Checking and adjusting the sensor

Check when required.

When checking is required, take the rear cover off and check the voltage level of No. 7 pin of IC4050 on the base and adjust the sensor bracket. When measuring the voltage level, the metal part of the main body is the ground.

When a screw is not at the pick up site, turn the power ON.

Next loosen the 2 sensor bracket attaching bolts and do the following:

- ①. Pull the sensor bracket down and check if the voltage is over 4V and if the sensor light is ON. At this time, the escaper is stopped.
- ②. Next, while checking the voltage level, slowly push the sensor bracket up which causes the voltage to decrease. When the voltage is around 0.25V ~ 1.5V tighten the sensor bracket. During this procedure when the voltage is around 2.5V, the LED screw indicator turns OFF and the escaper rotates.

When there is no screw at the pick up site, the voltage is 0.25V ~ 1.5V and the LED screw indicator is OFF.

When there is a screw at the pick up site and the voltage is over 3.5V, the LED screw indicator is ON. This is a general standard.

The borderline, if there is a screw in position or not, is 2.5V.

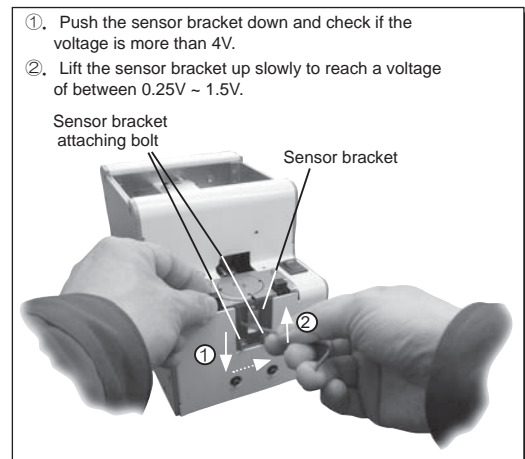
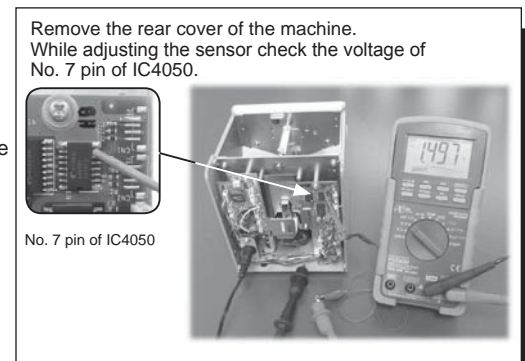
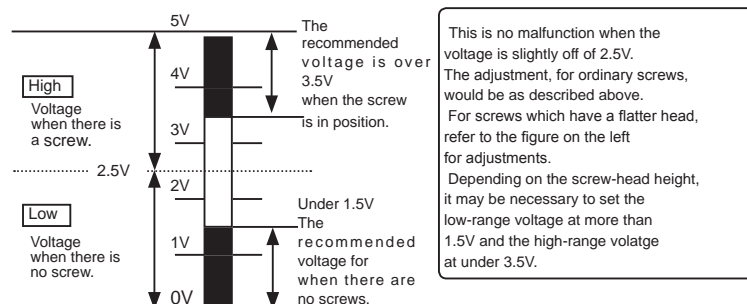

- 23 -

⑥. Operational check

After checking and adjusting each component, do an operational check with screws loaded.

If any abnormality is found, make the said adjustments once again in addition to the rail vibration and front/rear position adjustments.

After completing the operational check, return the wiring arrangement to its original status.

When installing the cover, take care not to catch or pinch the wires.

Watch that the wiring does not hinder the operation of this machine.

6- 6. Replacing the stopper

! Turn OFF the power switch before replacing.

The stopper is a consumable part. When the stopper is worn-off or damaged in shape, replacement is necessary to ensure proper machine operations.

(When stopper is being replaced, the escaper guide does not need to be removed from the machine.)

Part number: E-Stopper TPO-00512

- Release longer end of the stopper spring from the spring holder, and unfasten the spring end nut. When unfastening the end nut, please be cautious that the washer underneath may spring out.
- Disassemble the plain washer, stopper spring, and stopper in order.
- Install the new stopper, stopper spring, and washer in order. Fasten the end nut while holding down the plain washer in place. During this process, please be careful not to allow the spring to become trapped by spring end nut and plain washer.
- When the stopper spring assembly is completely fastened, fix the longer end of the spring onto the spring holder (as shown on right). Please check if the stopper can move freely, and that the bottom edge of the stopper is completely aligned and parallel with escaper guide.

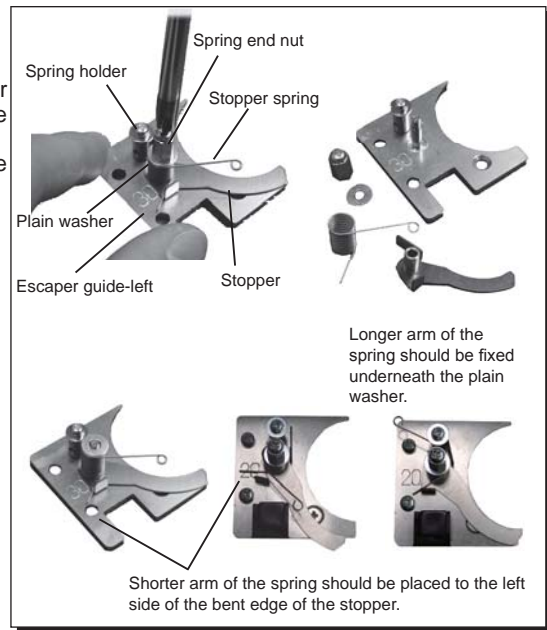

- 24 -

Please make sure the tip of the stopper does not touch the escaper, as it may interfere with the escaper's rotation.

If the end of the stopper is too close or too far from the escaper, please adjust the bent joint of the stopper where it makes contact with the spring holder, with a pair of long-nose pliers, so that the front of the stopper rests at the proper position.

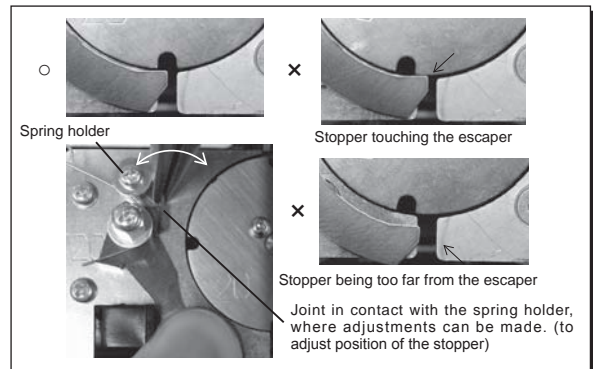

7. MISCELLANEOUS

7- 1. Overload protective circuit

This machine is equipped with an overload protective circuit.

Normally, the driving motor rotates forward to feed screws to the escaper continuously.

However, if there is an overload at the driving section, the driving motor rotates backward for a certain amount of time and then returns to normal rotation.

When the cause for the overload is removed, during the reverse rotation, the driving motor returns to the normal rotation. If the cause of the overload is not removed, during the reverse rotation, the driving motor repeats the sequence of reverse rotation/normal rotation, reverse rotation/normal rotation to shut off the power to the driving motor. During this time, the escaper action is not stopped.

When the power to the driving motor is shut off, turn OFF the power switch and remove the cause of the overload.

For example, when too many screws are loaded into the scooping chamber, reduce the quantity of loaded screws to a proper level. If any screw is caught in the transport section, remove it.

After removing the cause of the overload, turn ON the power switch to operate the machine.

(Power reset)

- 25 -

8. TROUBLESHOOTING



For safety, always unplug the AC adapter from the wall outlet before making any adjustments.

Trouble	Cause	Corrective measures
8-1 The machine does not operate though the power switch is turned ON.	<ul style="list-style-type: none"> • Power is not supplied. • The machine has not unloaded screws from the pick up site for a certain amount of time. • Too many screws were loaded into the scooping chamber. • A foreign object (for example: a screw) intruded into the main body. • The AC adapter is faulty. 	<ul style="list-style-type: none"> • Check the connection of the power supply of the AC power adapter. • Take out the screw from the pick up site. • Adjust the timer setting knob. • Reduce the quantity of screws in the scooping chamber to a proper load level. • Remove the foreign object. • Consult our service section. [Model number UI315-15]
8-2 Screws do not flow.	<ul style="list-style-type: none"> • Screws with a larger diameter than the specified rail size were loaded or screws with a different diameter were mixed in together. • An insufficient quantity of screws are in the scooping chamber. 	<ul style="list-style-type: none"> • Use screws with the specified nominal diameter. • Remove the screws with the odd nominal diameter. • Add a proper quantity of screws into the scooping chamber.

- 26 -

Trouble	Cause	Corrective measures
8-2 Screws do not flow.	<ul style="list-style-type: none"> • Screws in an abnormal position in the passing plate cannot be swept away with the brush. • The axis of the screw thread entered the passing plate. • A screw has stopped in an abnormal position while moving on the rail. • The rail does not vibrate. (For example, a screw is obstructing the clearance in scooping chamber.) 	<ul style="list-style-type: none"> • Adjust the brush. Adjust the passing plate. If a proper amount of screws are loaded into the scooping chamber, the status may be improved. Use the optional brush. (stiffer bristles) [Parts No: NSB02110a#02] • Remove the abnormal screw and check and adjust the passing plate. • Remove the screw in the abnormal position. Take care not to damage the rail groove. Move the bit guide bracket upward to remove the screw. After, adjust the position of the bit guide bracket in relation to height and direction. • Remove the screw that is obstructing the clearance. • Check the vibration adjustment. If no screw is obstructing the clearance, consult our service section.

- 27 -

Trouble	Cause	Corrective measures
8-3 A screw has fallen into the rail groove.	<ul style="list-style-type: none"> • Screws with a smaller diameter than the specified rail size were loaded. • Screws with a total length shorter than the rail groove width cannot be loaded. 	<ul style="list-style-type: none"> • Use screws with the specified nominal diameter and length. • No corrective measure is available. Consult our service section.
8-4 The flow on the screw rail is improper.	<ul style="list-style-type: none"> • The clearance between the bit guide bracket and the head of the loaded screw is narrow. • Screws with a spring washer having one increment smaller than the specified nominal rail size were loaded. • The rail is oily or dirty. • The rail does not vibrate. (A screw is caught in the clearance.) • The motor is worn. 	<ul style="list-style-type: none"> • Adjust the height of the bit guide bracket. Adjust the vibration. If, after following the instructions written above, the machine still does not function properly, consult our service section. • Clean the rail. • Remove the screws caught in the clearance. If there is no screw that is caught, consult our service section. • Adjust the vibration. • Replace the motor. [Part No: NSB 09182#05]

- 28 -

Trouble	Cause	Corrective measures
8-5 Screws tend to pass through the passing plate in an abnormal position. The axis of the screw thread tends to enter the passing plate.	<ul style="list-style-type: none"> • The passing plate is not adjusted properly. • Too many screws are in the scooping chamber. 	<ul style="list-style-type: none"> • Adjust the passing plate. • Reduce the quantity of screws to a proper level.
8-6 No screw comes to the pick up site.	<ul style="list-style-type: none"> • Screws are stopped while still on the rail. • Screws cannot be transferred smoothly from the rail to the escaper. 	<ul style="list-style-type: none"> • Adjust the height of the bit guide bracket. • Adjust the distance between the end of the rail and the escaper as well as the height of the escaper in relation to the rail.
8-7 The machine stops its operation suddenly.	<ul style="list-style-type: none"> • The overload protective circuit was activated. • Too many screws are in the scooping chamber. • A screw is caught in the clearance. • A screw, at the pick up site, could not be picked up for an amount of time. 	<ul style="list-style-type: none"> • Turn the machine OFF and then ON again. • Remove the cause of overload. • Remove screws to a proper level. • When the machine stops, even if the screws are at a proper level, consult our service section. • Remove the screw that is caught. • Remove the screw.

- 29 -

Trouble	Cause	Corrective measures
8-8 The scooping operation does not stop though screws are at the pick up site.	<ul style="list-style-type: none"> The timer knob is not properly adjusted. 	<ul style="list-style-type: none"> Readjust the timer knob.
8-9 The escaper operation does not stop though screws are at the pick up site.	<ul style="list-style-type: none"> The sensor does not detect a screw. 	<ul style="list-style-type: none"> Readjust the voltage of the sensor.
8-10 A screw has fallen into the machine.		<ul style="list-style-type: none"> Shake the screw down through the hole at the bottom of the machine.
8-11 The noise of the machine has increased.	<ul style="list-style-type: none"> There is insufficient grease. 	<ul style="list-style-type: none"> Apply grease to the transport section. <ul style="list-style-type: none"> Recommended grease: <ul style="list-style-type: none"> BR2 Plus , Dow Corning Asia Co. Ltd.

- 30 -

Trouble	Cause	Corrective measures
8-12 The escaper does not rotate when no screws are present, although the indicator light is on.	<ul style="list-style-type: none"> Undesired objects blocking front screw sensor. Adjustment of the front screw sensors is unsuitable. 	<ul style="list-style-type: none"> Make sure there are no debris or other objects present in the sensor brackets. If the escaper or stopper is damaged or worn-off, parts replacement is recommended. Adjustment on front screw sensors as shown on P.23.
8-13 The escaper rotates in the wrong direction.	<ul style="list-style-type: none"> When the escaper is operating, some alien object is preventing the escaper from rotating smoothly. Escaper and the escaper guide do not fit together. 	<ul style="list-style-type: none"> Please check if the bit-guide and its mounting bracket are both positioned correctly so that sensors are not interfered or blocked, and that the screw can move freely. If the escaper or escaper guide is damaged or worn off, replacement is recommended.
8-14 The escaper continues to rotate in the wrong direction.	<ul style="list-style-type: none"> The origin sensor may be improperly adjusted. 	<ul style="list-style-type: none"> Please contact your dealer or our service section.

- 31 -

10. SPECIFICATIONS

Power AC adapter (switching type)	Input: AC100~240V 50/60Hz Output: DC15V 1A
Dimensions	123(W) × 181(D) × 145(H) (mm)
Weight	Approx. 3Kg (including rail)
Screw capacity	Approx. 80cc
Following accessories	Operation Manual 1 copy AC Adapter 1 unit Passing Plate 2 pieces (one is already installed.) Hexagonal Wrench 1 piece Screwdriver 1 piece

Notes :

- Please consult your distributor for thin head.
- Check if the axis diameter of the loaded screw corresponds with the below rail groove width.
- With the range of screw size and lengths below, there may be instances of unique screw shape or structure not compatible with the screw feeder unit.
- In the main body type, the main body model can be changed.
- To change the nominal diameter of loaded screw, replace it with a part that is mentioned in the next page table.
- The rail, escaper, stopper assembly, escaper guide-right and passing plate are separately available for replacement.
- The design, performance and specifications are subject to change without prior notice for the sake of improvement.

Reference table of the specified screws					Shape of screw head						
					Pan head			bind	Flat head	Counter sunk head	hexagon flange bolt
Screw size	Screw shaft diameter (φ)	Screw head diameter (φ)	Screw head thickness (mm)	Screw shaft length (mm)	Sems	Double sems	Washer head				
M1.0	0.9~0.95	1.2~4.5	0.35~1.0	1.6~10					○		
M1.2	1.1~1.15	1.4~4.5	0.35~1.0	1.8~10					○		
M1.4	1.3~1.4	1.7~4.5	0.35~1.0	2.0~10					○		
M1.7	1.6~1.7	2.0~4.5	0.35~1.0	2.3~10					○		
M2.0	1.9~2.1	2.4~6	0.35~4.5	2.6~20	○	○	○	○	○	○	○
M2.3	2.2~2.4	2.7~6	0.35~4.5	2.9~20	○	○	○	○	○	○	○
M2.6	2.5~2.7	3.0~6	0.35~4.5	3.2~20	○	○	○	○	○	○	○
M3.0	2.9~3.2	3.5~6	0.35~4.5	3.6~20	○	○	○	○	○	○	○

※ Compatible with washer diameter up to 9 mm, thickness 0.35 to 1.0mm.

Screw feeder series	Screw feeder model	Screw size	Exchange kit No.	Rail model No.	Escaper model No.	Stopper assembly model No.	Escaper guide-right model No.	Passing plate model No.
NSBI	NSBI10	φ 1.0	BI10SET	BI10	SIE10	SIES10	SIEM10	SW1017
	NSBI12	φ 1.2	BI12SET	BI12	SIE12	SIES12	SIEM12	
	NSBI14	φ 1.4	BI14SET	BI14	SIE14	SIES14	SIEM14	
	NSBI17	φ 1.7	BI17SET	BI17	SIE17	SIES17	SIEM17	
	NSBI20	φ 2.0	BI20SET	BI20	SIE20	SIES20	SIEM20	SW2030
	NSBI23	φ 2.3	BI23SET	BI23	SIE23	SIES23	SIEM23	
	NSBI26	φ 2.6	BI26SET	BI26	SIE26	SIES26	SIEM26	
NSBI30	φ 3.0	BI30SET	BI30	SIE30	SIES30	SIEM30		

※ In the Exchange kit ordered, Rail assembly, Escaper, Stopper assembly and Escaper guide-right are included.

○ Replacement parts

• Rail

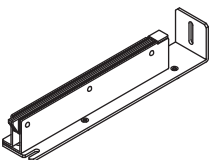

• Escaper

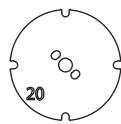

• Stopper assembly

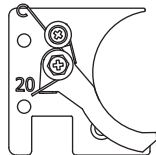

• Escaper guide-right

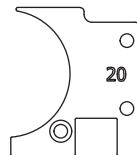

• Passing plate



• Stopper TPO00512

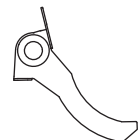

• Main motor unit NSIB7115

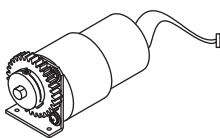

• Brush assembly NSB02053 #01

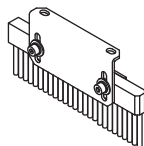

• Bit guide assembly NSIB6103

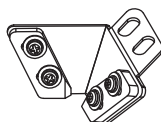

1 0. EXTERNAL DIMENSIONS

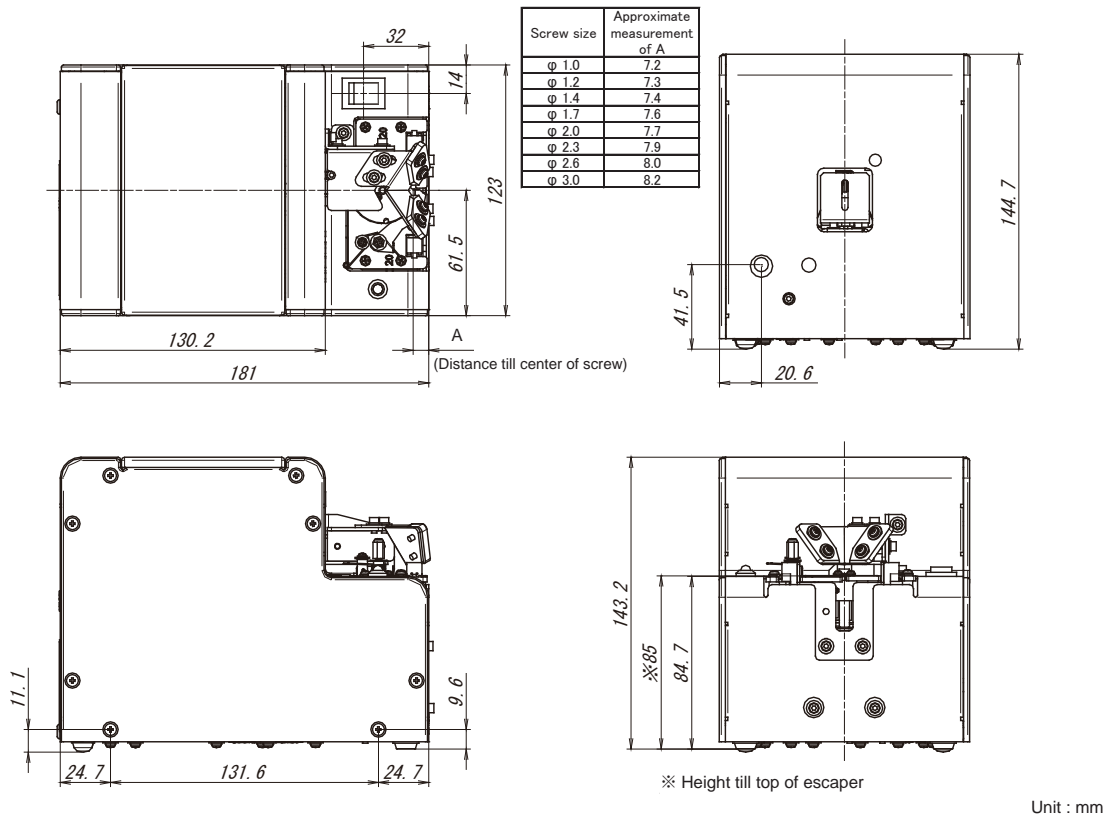

- 34 -

1 1. WARRANTY

For users within Japan, the effective term of warranty is 6 months after delivery.

Such warranty will not be applicable to purchases or users outside of Japan.

If any troubles should occur, please contact your dealer.

After the warranty period, repair services will be completed.

In the following cases, the purchaser shall pay for parts and labor regardless of the terms of warranty:

- ① Failure due to improper handling.
- ② Failure due to product modification or improper processing.
- ③ Failure due to causes beyond control (for example earthquake or fire).
- ④ Failure attributable to any cause other than this product.
- ⑤ Consumables (brushes, main motor, bit guide, escaper, escaper guide, stopper) and replaceable parts and replacement work expenses.

The repair parts shall be available within 5 years after purchase.

- 35 -

<http://www.ohtake-root.co.jp>

株式会社 大武・ルート工業

岩手県一関市萩荘字金ヶ崎 27 丁 021-0902
Tel +81-191-24-3144
Fax +81-191-24-3145

OHTAKE-ROOT KOGYO CO.,LTD.

27 Kanegasaki Hagisho Ichinoseki
Iwate, 021-0902 JAPAN
Tel +81-191-24-3144
Fax +81-191-24-3145

「Quicher」「OHTAKE」「OHTAKE・ROOT KOGYO」are trademarks or/and registered trademarks of OHTAKE・ROOT KOGYO CO.LTD.
「Quicher(クイッチャー)」「OHTAKE」「OHTAKE・ROOT KOGYO」は、株式会社 大武・ルート工業の商標又は登録商標です。

The specifications and/or design may be altered, without notice, whenever there are changes or improvements.
改良のため、予告なくデザイン、性能、仕様等を変更することがあります。

Photocopying, reproduction or publication, in whole or in part, of this manual, without permission, is strictly prohibited by copyright law.

この取扱説明書の一部または全部の無断転載、複製を禁じます。

© Copyright OHTAKE・ROOT KOGYO CO.,LTD.

(as of July, 2016)

(2016年7月現在)